

Ankara Pressure Vessels & Process Equipment

ANKA STRAINER SERIES

ANKA Multi Media Filter



Technical Specifications

VOLUME
500 - 12000
L max

Flow Rate
5 – 65
m³/h

STANDARD DESIGN PRESSURE
10
barg

DESIGN TEMPERATURE
80
°C

ELLIPTICAL HEADS

EUROPE TRANSPORT-
ORIENTED SIZING

ANKA Multi Media Filter - Complete Model Range

Filter Model	Flow Rate m ³ /h	Nominal Volume (L)	Manhole	Weight (Kg)	Dimensional Data (mm)		
					A	B	C
MMF500-5	5	500	DN400 / PN10	420	750	935	1400
MMF750-5	5	750	DN400 / PN10	470	750	1550	2000
MMF1000-5	5	1000	DN400 / PN10	530	750	1990	2450
MMF1000-8	8	1000	DN400 / PN10	470	950	1500	2200
MMF1500-10	10	1500	DN400 / PN10	670	1050	1500	2350
MMF1500-12	12	1500	DN400 / PN10	720	1125	1500	2200
MMF1800-12	12	1800	DN400 / PN10	800	1150	1500	2350
MMF2200-16	16	2200	DN500 / PN10	890	1300	1500	2350
MMF2500-17	17	2500	DN500 / PN10	960	1350	1600	2480
MMF3000-19	19	3000	DN500 / PN10	1230	1430	1680	2550
MMF3500-22	22	3500	DN500 / PN10	1320	1540	1680	2550
MMF4000-26	26	4000	DN500 / PN10	1410	1650	1680	2550
MMF5000-32	32	5000	DN500 / PN10	1560	1850	1680	2550
MMF 6000-35	35	6000	DN500 / PN10	1750	1850	2000	3100
MMF 7500-45	45	7500	DN500 / PN10	1980	2100	2000	3250
MMF 10000-55	55	10000	DN500 / PN10	2250	2400	2000	3250
MMF 12000-65	65	12000	DN500 / PN10	2550	2650	2000	3350

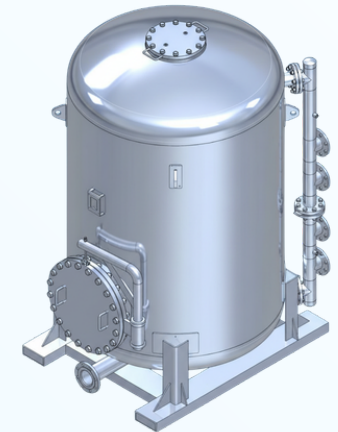
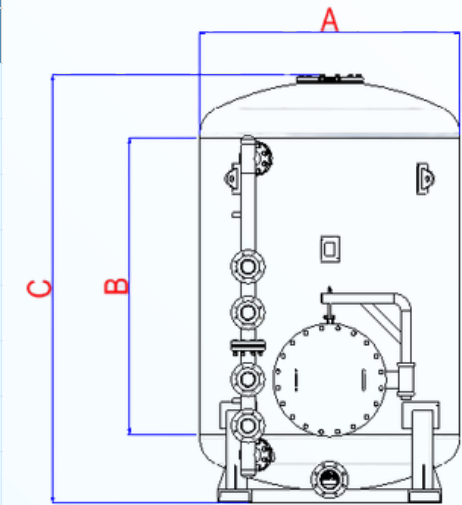

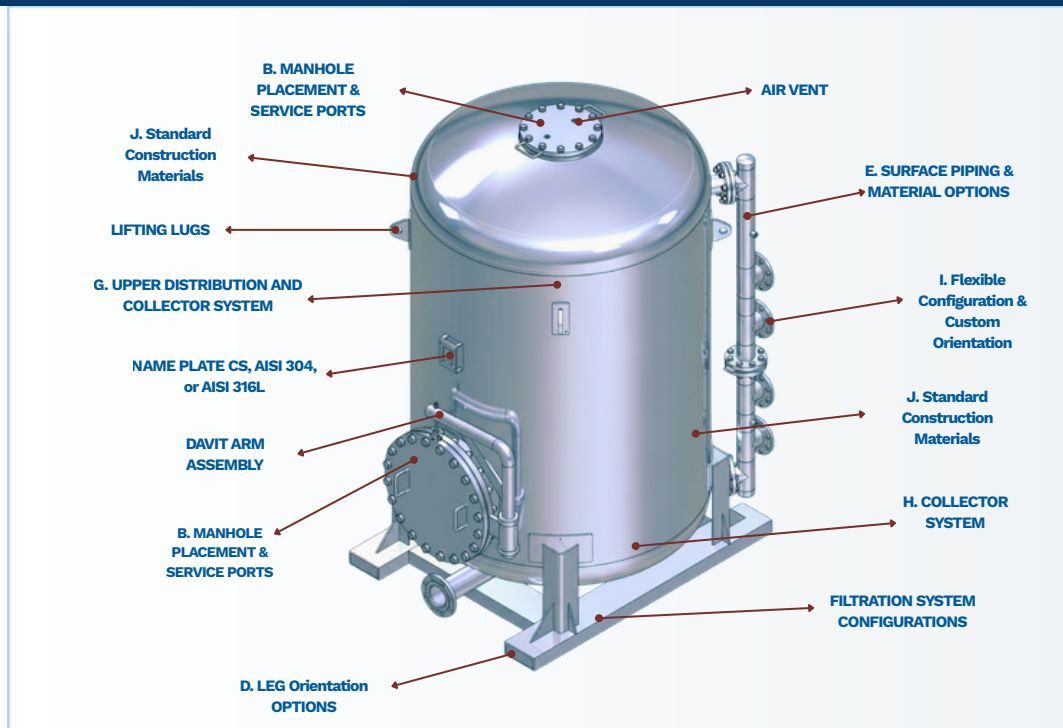

FILTER PROCESS

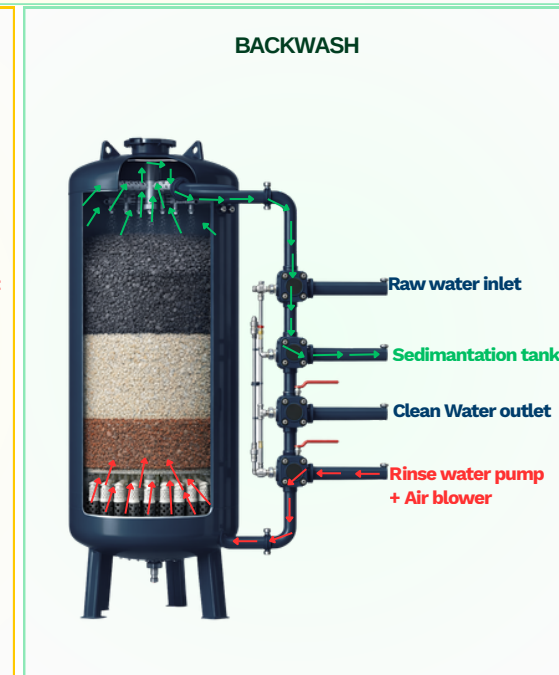
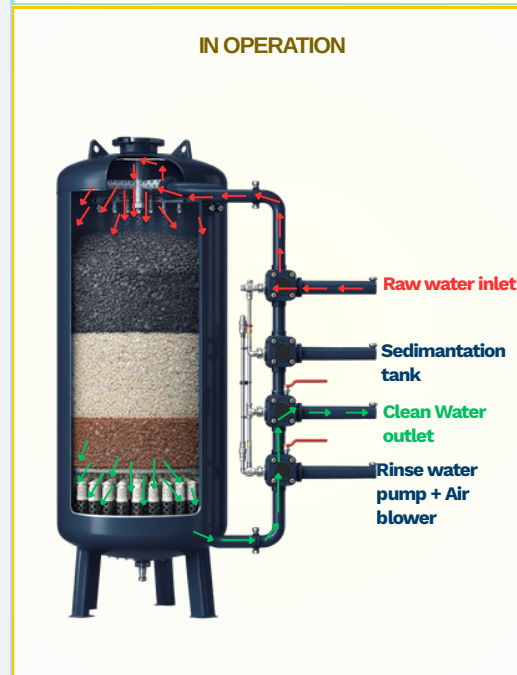

A. FILTRATION SYSTEM CONFIGURATIONS

SINGLE FILTER UNITS

Compact and independent solutions for low to medium flow applications.



Reliable single-vessel filtration with easy maintenance and minimal space requirements.

SKID-MOUNTED MODULAR SYSTEMS

High-capacity, plug-and-play solutions for large-scale projects requiring continuous operation.

Continuous Water Supply: While one tank is undergoing backwashing, the others remain in service; the water flow is never interrupted.

Scalable Capacity: Capacity can be easily increased by connecting 2, 3 and maximum 4 tanks in parallel as needed.

Turnkey Solution: The piping, valves, and control panel are pre-assembled on a single skid, forming a fully tested, ready-to-use system (Plug-and-Play).

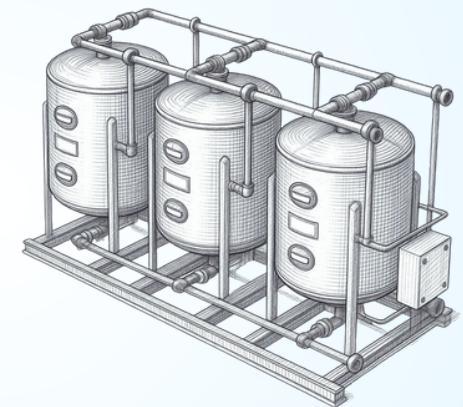

B. MANHOLE PLACEMENT & SERVICE PORTS

Customizable Manhole Locations



Customizable manhole placement based on specific internal hardware and service needs.

Elliptical Manhole with External Climp



Unlike standard flat lids, these lids have a curved/oval (elliptical) shape to ensure a perfect fit with the tank's cylindrical body. When closed, the lid sits almost flush with the tank's outer surface and does not protrude outward with a large flange. Ideal for tanks where space constraints or other design factors make a round manhole difficult to install or operate.

STANDARD MANHOLE WITH DAVIT ARM ASSEMBLY

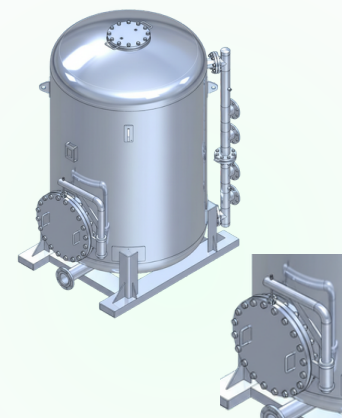

Heavy-duty davit arm system designed for the safe and effortless handling of large manhole covers during inspection and maintenance.

Side Glass - Hand Hole Options

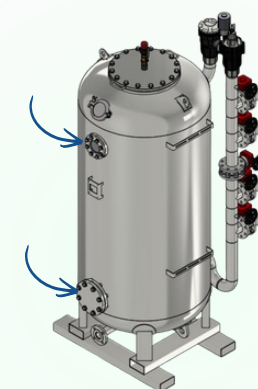

Integrated sight glasses for real-time media monitoring and hand holes designed for quick access to internal distribution components.

C. STRUCTURAL CONFIGURATIONS & ACCESSIBILITY

WITH SERVICE PLATFORM



Integrated safety platforms with caged ladders and handrails designed for secure top-entry maintenance and operator safety on large-scale vessels.

WITHOUT PLATFORM



Streamlined, space-saving configuration featuring a vertical valve manifold designed for easy ground-level operation and maintenance.

D. LEG ORIENTATION OPTIONS

2-Way Forklift Entry

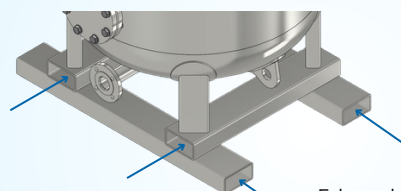

Enhanced mobility with secure two-sided lifting access for easy transport.

Single Layer / One-Way

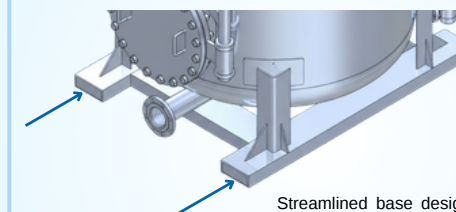

Streamlined base design optimized for stable and direct floor installation.

ASME SHELL-WELDED LEGS



In compliance with ASME standards for enhanced safety and pressure vessel stability.

DOVE-WELDED TUBULAR LEGS



Tubular legs welded to the dome to minimize the overall vessel footprint.



E. SURFACE PIPING & MATERIAL OPTIONS

1. STAINLESS STEEL PIPING



High-durability, corrosion-resistant piping solution ideal for pharmaceutical, food-grade applications, and harsh industrial environments.

2. GALVANIZED STEEL PIPING

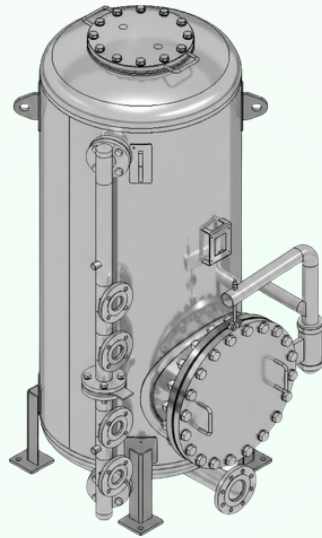

A robust and cost-effective piping option providing excellent mechanical strength and atmospheric corrosion protection for standard water treatment.

3. THERMOPLASTIC (PVC/PP) PIPING



Lightweight, chemical-resistant, and non-corrosive piping system designed for aggressive fluid handling and budget-optimized installations.

F. CONTROL PANEL ALIGNMENT



Available as a complete system with an integrated control panel or as a standalone unit without a panel.

G. UPPER DISTRIBUTION AND COLLECTOR SYSTEM

G1. Block Distributors

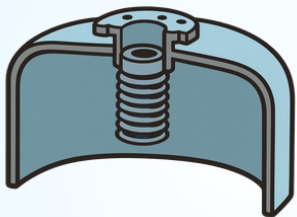

Stainless steel options

Upper distribution systems for sand and activated carbon filters
Material: PP, SS316L, SuperDuplex, special alloys

G2. LATERAL / ARM SYSTEM

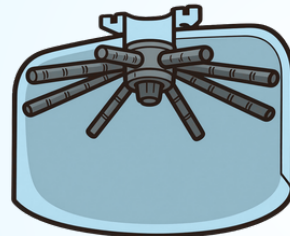

Engineered for uniform flow distribution across the entire media surface.
Material: PP, SS316L, SuperDuplex, special alloys

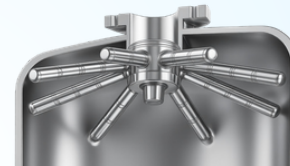

Stainless Steel options
Long life, resistance to corrosion and high temperature resistance

G3. Splash Plate (Inlet Splash Plate)

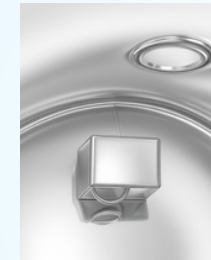

Splash plate to dissipate inlet jet energy and pre-distribute flow across the filter bed.



H. COLLECTOR SYSTEM

H1. Plate Nozzles (Mushroom Diffusers)

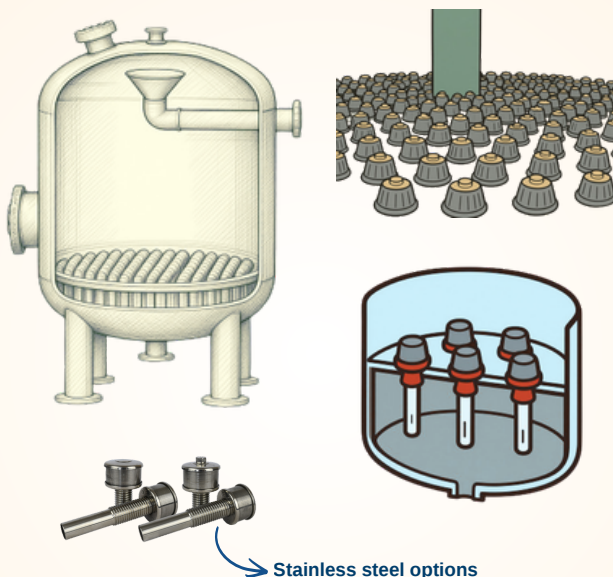

- Slot Spacing: Various options ranging from 0.20 mm to 5.0 mm.
- Installation Note: Countersinks must be drilled in the plate holes to prevent damage to the bolts during expansion.
- Material: PP, SS316L, SuperDuplex, special alloys

H2. Round Pipe Nozzles

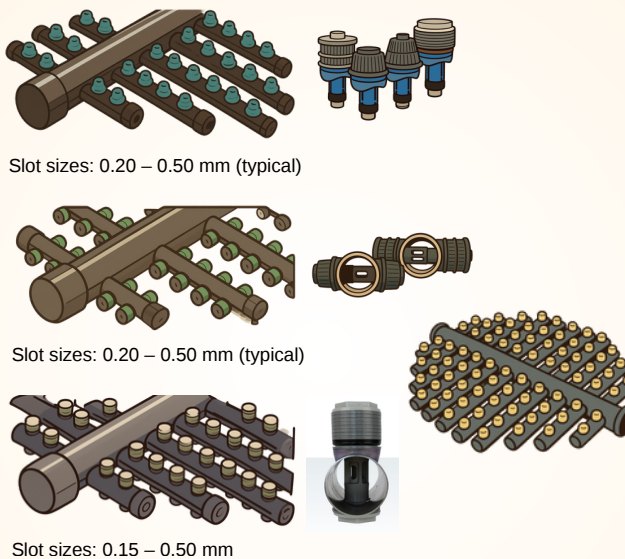

- Shipped pre-assembled, reducing installation time.
- Application: A more economical drainage alternative compared to nozzle plate systems.
- Material: PP, SS316L, SuperDuplex, special alloys

H3. LATERAL / ARM SYSTEM

Inexpensive distribution and drain system for small filters with narrow opening
Material: PP, SS316L, SuperDuplex, special alloys

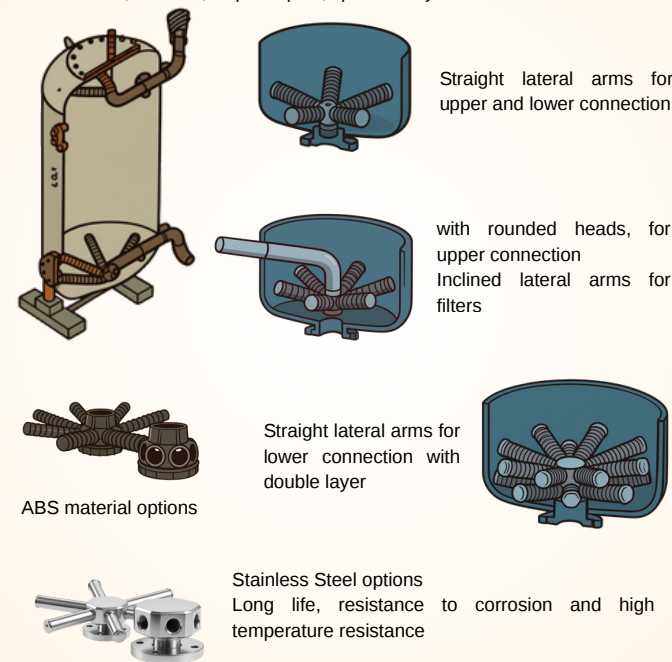

H4. Filter arms for drain and distribution systems

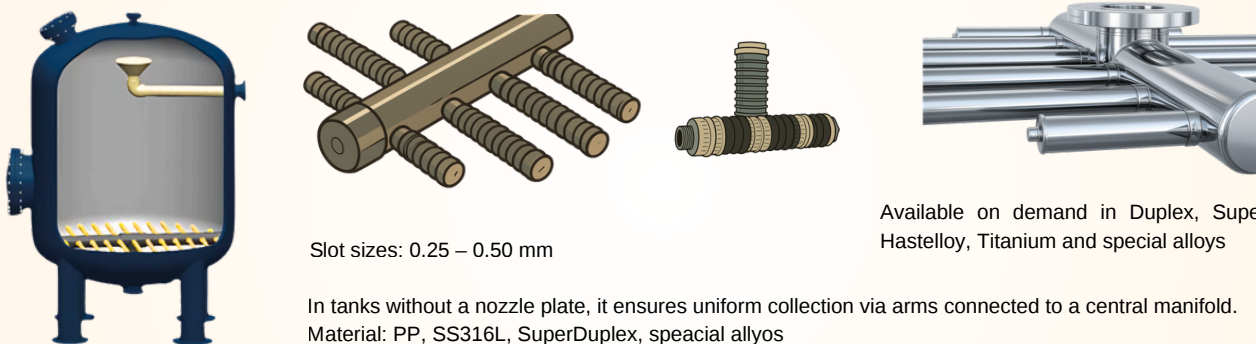

Slot sizes: 0.25 – 0.50 mm

In tanks without a nozzle plate, it ensures uniform collection via arms connected to a central manifold.
Material: PP, SS316L, SuperDuplex, special alloys

H5. Bottom distributors

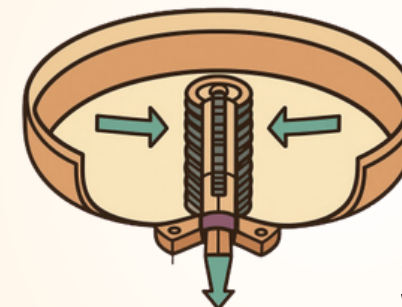

Flat-plate collector systems mounted on a base plate or with a central pipe.

I. Flexible Configuration & Custom Orientation

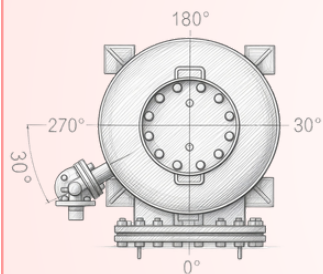

Manifold Orientation Options

Standard and custom angle configurations (30° / 90° / Custom) are available to provide maximum installation flexibility and optimized flow paths.

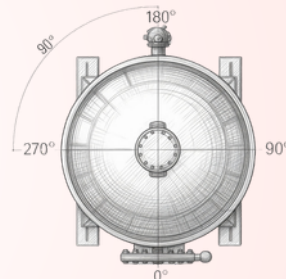

J. Standard Construction Materials

Housing & Lid Materials

- ✓ Carbon Steel with epoxy coating
- ✓ Stainless Steel 304/304L
- ✓ Stainless Steel 316/316L
- ✓ Super Duplex (special applications)

Flanges & Connections Materials

- ✓ B16.5 Class 150/300/600 SO/WN RF/FF
- ✓ EN1092-1 PN10/16/25/40 FF
- ✓ ASME B16.47 for large sizes
- ✓ Custom flange standards available

K. Medias

Basic Operating Principle (Deep Filtration)

While in standard sand filters water is filtered only through the top layer, in multimedia filters the water is directed to pass through all layers.

- **Top:** Larger but lighter anthracite is located here. It traps large particles.
- **Middle:** Smaller and heavier sand is located here. It traps medium-sized particles.
- **Bottom:** Garnet, which is the smallest and heaviest, is located here. It captures the smallest particles.

This ensures that not just the surface but the entire depth of the filter acts as a sieve. This prevents the filter from clogging as quickly and allows it to operate more efficiently.

MEDIA LOADING

1. Open filter's lid (the filter must not be emptied without opening the lid, as it could collapse) and keep the filter tank with half water.
2. Start filling the tank with gravel approximate 10cm above lateral arms, then Add Media in Correct Sequence For multi-layer filters: **gravel → garnet → sand → carbon.**

*This must be done steadily in small amount in order to avoid any damage of the lateral arm layer of the filter.

*When the filter is being filled with sand, it is necessary to flatten the sand surface and distribute evenly.

MEDIA REMOVAL

1. Remove top lid
2. Drain filter's water through the lower drainage hole.
3. Sand should be removed through the manhole.
4. To refill the filter with sand checking first of all that the drainage hole has been perfectly fitted and that it does not leak water.

Filter Media Layers — Visual Guide

This is the 40% void space at the top of the tank. This void space is necessary to allow the media layers to rise and expand during the "Backwash" process.



Freeboard
(> 40% required)

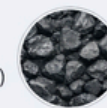

Anthracite is a natural mineral used as a top layer filtration mineral in multimedia sand filters.

Quartz Sand



It is used as a filtration medium or substrate depending on the suspended solid particle size and application.

Garnet 30x40



It is laid over the 8x12 sheet to perform the primary fine filtration function.

Garnet 8x12



It acts as a "support bed" in the lower layer, preventing the nozzles from clogging.

Support Gravel
to cover laterals



This layer does not filter; it simply prevents the collection pipes (laterals) below from clogging and serves as a support for the media.



Industries We Serve



Sewage Treatment Industry



Food Processing Facilities



Cement Manufacturing



Chemical Plants



Petrochemical



Mining Operations



Pulp and Paper



Steel Mills

Why Choose Us



Engineering Excellence

Over 20 years of experience in pressure vessel and filtration equipment design and manufacturing. Our engineering team provides custom solutions tailored to your specific requirements.

Quality Assurance

All products manufactured to international standards (ASME, PED, EN13445) with comprehensive testing and third-party inspection. Full material traceability and documentation.



Global Support

Technical support, installation guidance, and after-sales service provided worldwide. Extensive spare parts inventory and fast delivery to minimize downtime.

Get in touch with us today!

EMAIL

info@pressurevesselequipment.com

PHONE

+90 541 925 20 14

WEBSITE

<https://www.pressurevesselequipment.com>

ADDRESS

İvedik OSB, İvedik Organize Sanayi Bölgesi, 1364. Sk. No:12, 06378 Yenimahalle/Ankara

