

Ankara Pressure Vessels & Process Equipment

ANKA AUTOMATIC FILTERS

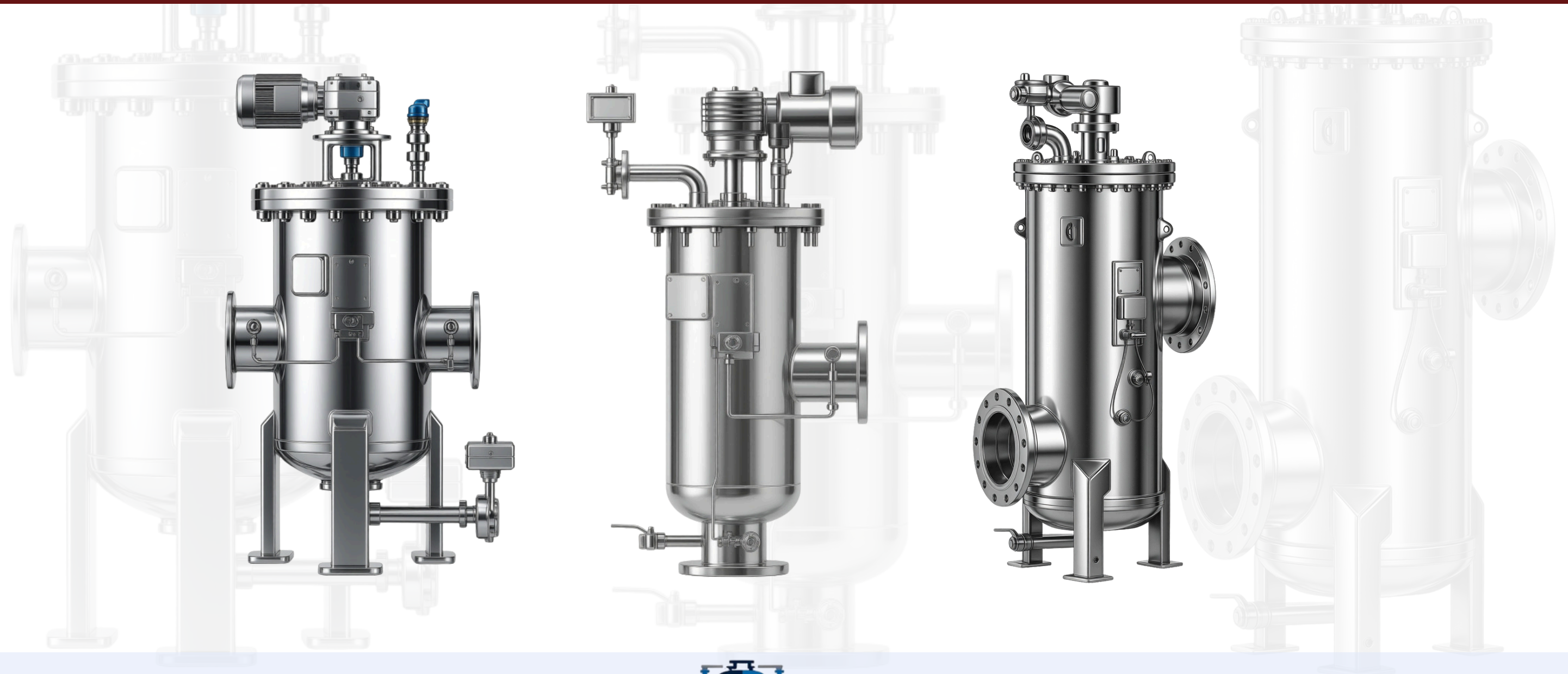

Technical Specifications

4,500 m³/h MAX FLOW RATE	100 — 5,000 μm FILTRATION DEGREES	1 bar (15 psi) MIN. OPERATING PRESSURE	DN80 — DN800 INLET/OUTLET	FILTRATION Area 3100–50,000 μm	Inlet/Outlet Connection Configurations
-----------------------------------------------	---------------------------------------------	--------------------------------------------------	-------------------------------------	----------------------------------------------------	---------------------------------------------------------

ANKA AUTOMATIC FILTERS - Complete Model Range

Filter Model	Inlet/Outlet DN	Flow Rate m ³ /h	Filtration Area cm ²	Weight kg	Motor kW	Air Vent / Drain	Lid Closure System	Dimensional Data			
								A* mm	B mm	C mm	D mm
AAF 80	DN80 (3")	45	3,100	180	0.37	DN40	Type 1	600	850	605	120
AAF 100	DN100 (4")	75	3,100	183	0.37	DN40	Type 1	600	850	605	120
AAF 125	DN125 (5")	115	4,500	202	0.37	DN40	Type 1	660	1,040	645	125
AAF 150	DN150 (6")	170	4,500	208	0.37	DN50	Type 1	660	1,040	650	125
AAF 200	DN200 (8")	290	7,250	330	0.55	DN50	Type 1	745	1,200	800	150
AAF 250	DN250 (10")	460	7,250	345	0.55	DN50	Type 1	745	1,200	800	150
AAF 300	DN300 (12")	650	12,000	568	0.55	DN65	Type 1	800	1,400	950	150
AAF 350	DN350 (14")	800	12,000	582	0.55	DN65	Type 1	800	1,400	950	150
AAF 400	DN400 (16")	1,060	16,000	874	0.75	DN80	Type 1	1,000	1,560	1,200	150
AAF 450	DN450 (18")	1,355	16,000	911	0.75	DN80	Type 1	1,000	1,560	1,200	150
AAF 500	DN500 (20")	1,690	22,000	1,681	1.50	DN100	Type 1	1,100	1,730	1,600	200
AAF 600	DN600 (24")	2,500	30,000	1,891	1.50	DN100	Type 1	1,280	2,080	1,600	250
AAF 700	DN700 (28")	3,900	42,000	2,980	2.20	DN150	Type 1	1,470	2,270	2,000	250
AAF 800	DN800 (32")	4,500	50,000	3,226	2.20	DN150	Type 1	1,570	2,570	2,000	250

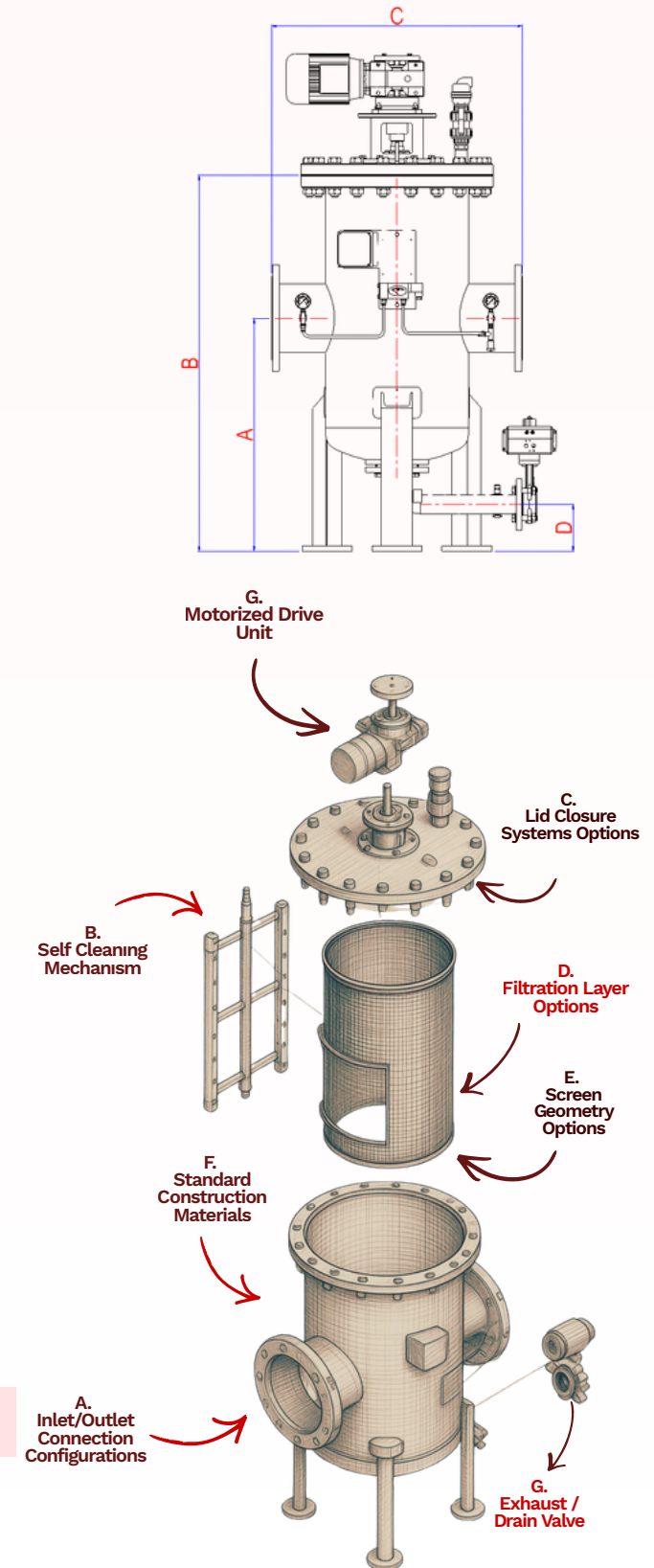

Note: *A Dimension can be adjusted according to site piping elevation.

A. INLET/OUTLET CONNECTION CONFIGURATIONS

Standard In-Line (Parallel)

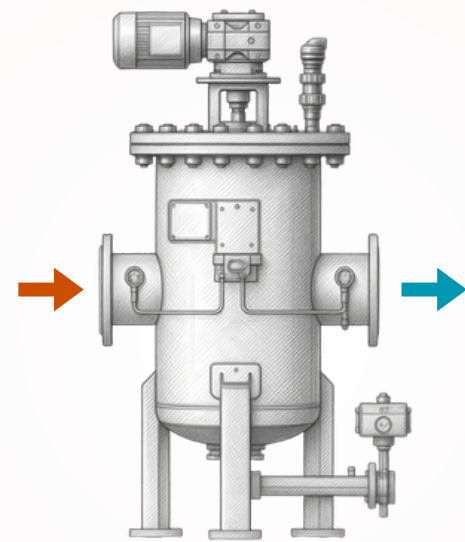

Inlet and outlet are positioned at the same level on opposite sides, allowing for simple integration into horizontal pipelines.

Offset In-Line

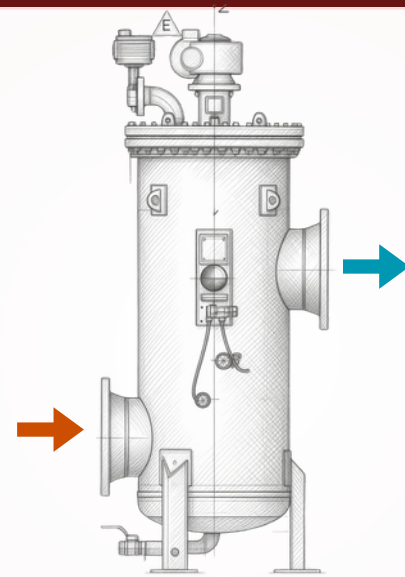

One port is positioned lower than the other to accommodate piping elevation differences or specific flow requirements.

Angle/Vertical In-Line

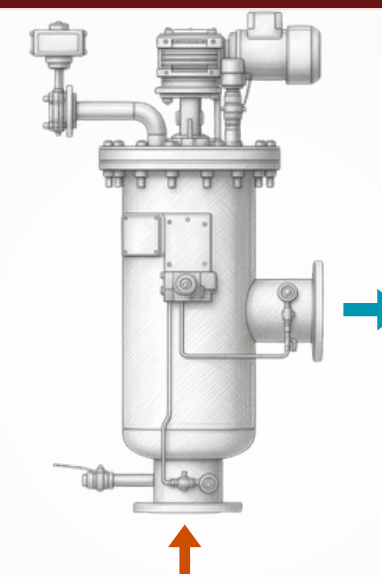

Inlet is at the bottom (vertical) and outlet is on the side, ideal for space-saving vertical installations or specific process turns.

B. SELF CLEANING MECHANISM

Brush Cleaning Mechanism

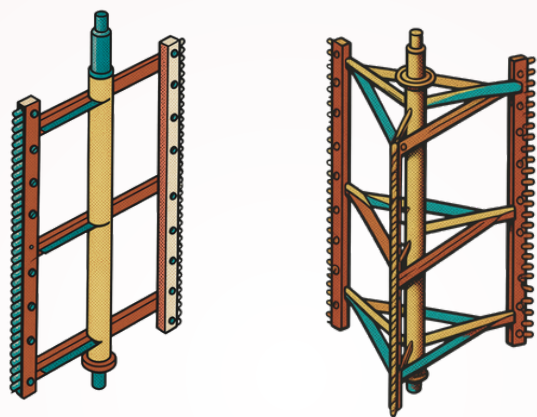

Rotating brush assembly driven by the motor scrubs the inner surface of the screen, effectively removing accumulated particles. Suitable for general applications and medium solids load.

Scraper Cleaning Mechanism

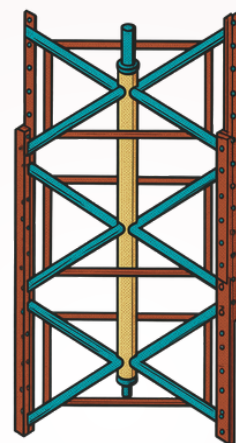

Rigid scraper elements mechanically remove deposits from the screen surface. Preferred for sticky or heavier solids where brushing may not be sufficient.

Scanner Nozzle Cleaning Mechanism

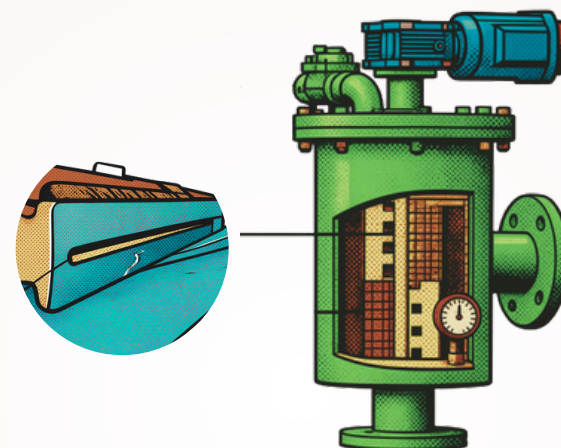

Suction-based scanning nozzles move across the screen surface to vacuum trapped particles. This non-contact method ensures efficient cleaning with continuous filtration and is ideal for removing fine debris without damaging the screen mesh.

Vacuum Cleaning Mechanism

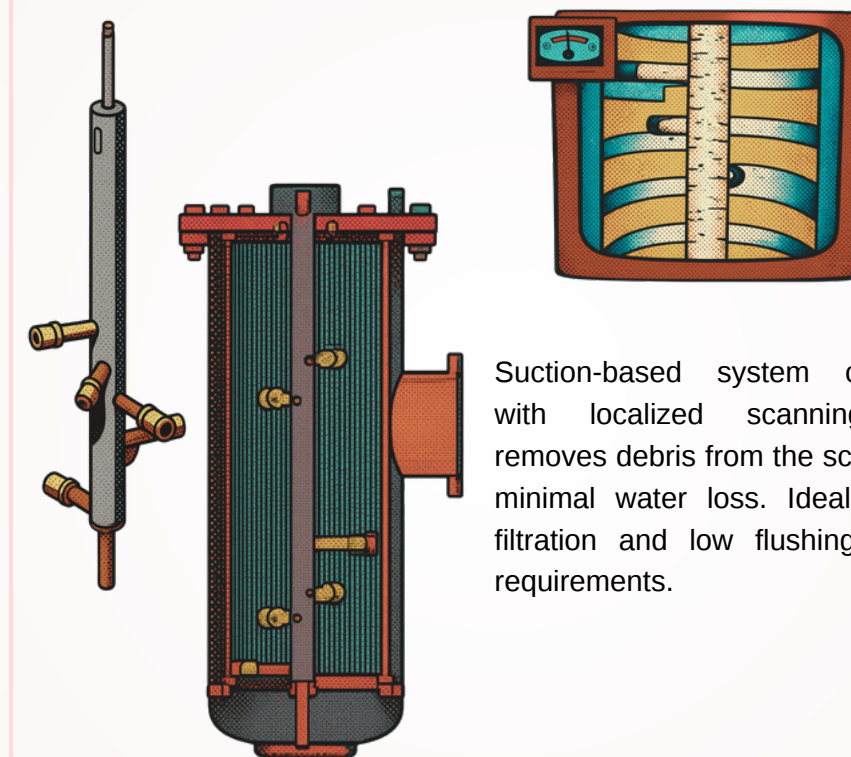

Suction-based system combined with localized scanning arms removes debris from the screen with minimal water loss. Ideal for fine filtration and low flushing volume requirements.



E FILTRATION LAYER OPTIONS

Perforated Screen



Available Ratings:

5,000 • 3,500 • 3,000 • 2,500 • 2,000 • 1,500 • 1,000 micron

Material: SS304, SS316, Duplex, SDSS, SMO

Design: Punched circular holes in stainless sheet

Best for: Coarse filtration, high-flow applications, debris removal

Wedge Wire Screen



Available Ratings:

800 • 500 • 300 • 200 • 100 micron

Material: SS304, SS316, Duplex, SDSS, SMO

Design: V-shaped wires welded to support rods

Best for: Fine filtration, non-clogging, high strength applications

D. SCREEN GEOMETRY OPTIONS

Inlet Frame Cut



- Maximum Area Ratio
- Fully Inline Design (see inlet frame cut figure)
- Bypass possibility exists therefore good for coarse filtration
- Cost effective for pressures up to 4 barg.

FLOW PATTERNS

Inlet Frame Cut

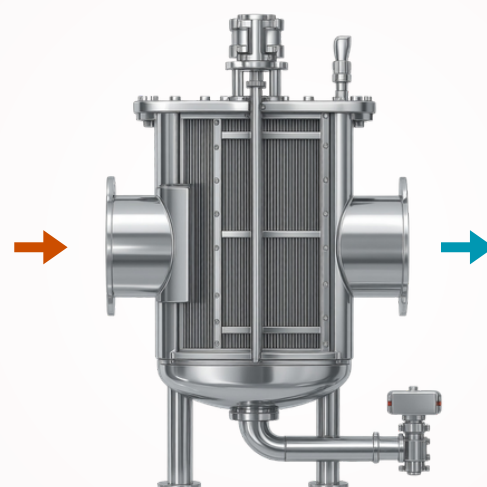

D. SCREEN GEOMETRY OPTIONS

Full Circular



- Best Bypass Avoidance
- Smallest Area but good for fine filtration
- Flexible nozzles according to piping requirement.
- Area Lost, Larger Housing Required
- Structurally Strongest

FLOW PATTERNS

Full Circular

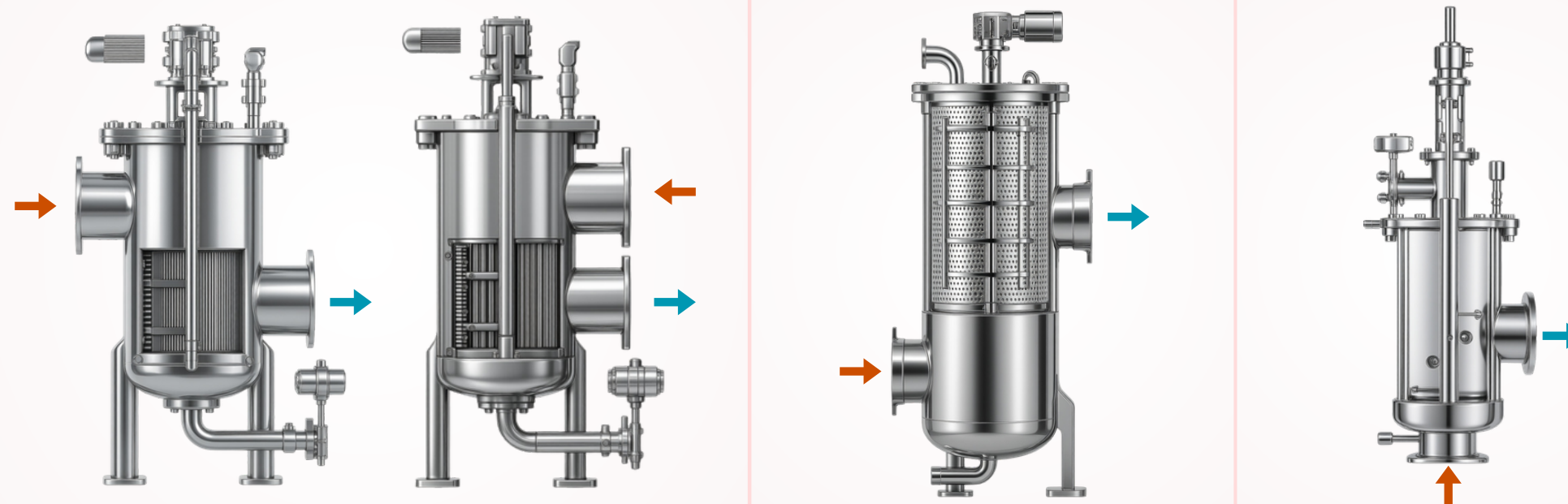

C. LID CLOSURE SYSTEMS — Select by Model Size

STANDARD BOLTED COVER SYSTEM

1



HYDRAULIC JACK-LIFTING LID

2

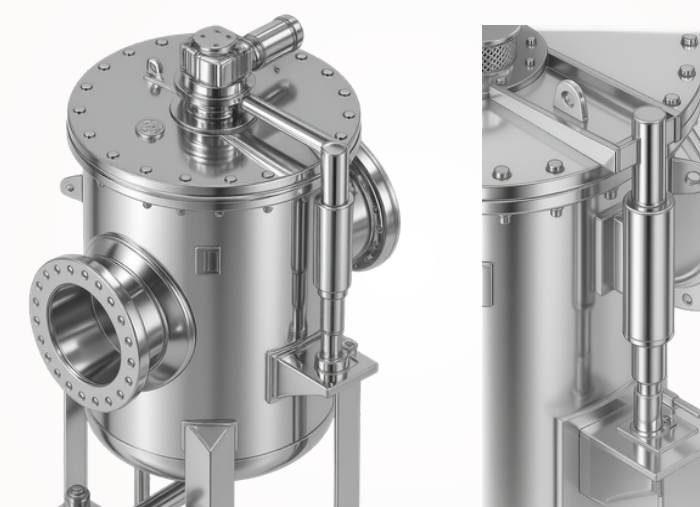

F. STANDARD CONSTRUCTION MATERIALS

Housing & Lid Materials

- ✓ Carbon Steel with epoxy coating
- ✓ Stainless Steel 304/304L
- ✓ Stainless Steel 316/316L
- ✓ Super Duplex (special applications)

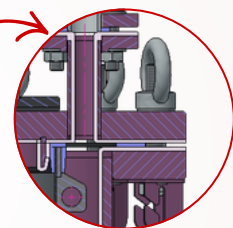

Seals & Gaskets Materials

- ✓ NBR (Nitrile Rubber) - standard
- ✓ EPDM (for water applications)
- ✓ PTFE (chemical resistance)
- ✓ Viton (high temperature)

Flanges & Connections Materials

- ✓ B16.5 Class 150/300/600 SO/WN RF/FF
- ✓ EN1092-1 PN10/16/25/40 FF
- ✓ ASME B16.47 for large sizes
- ✓ Custom flange standards available

Screen Elements Materials

- ✓ SS304, SS316, Duplex, SDSS, SMO
- ✓ Wire Mesh Lined options
- ✓ Double Layer Reinforced for high ΔP
- ✓ Custom materials upon request

G. CONTROL & ACTUATION SYSTEM

The Automatic Series filters are equipped with an integrated control and actuation system ensuring fully automatic and reliable self-cleaning operation.

Motorized Drive Unit

Electric motor (0.37 – 2.2 kW, 380V AC, 3 Phase) drives the internal brush mechanism via a stainless steel shaft, enabling effective cleaning of the filter screen.

Exhaust / Drain Valve:

Discharge of debris is performed through a pneumatically actuated butterfly valve (optional electric or hydraulic actuation available), ensuring efficient removal of solids during the cleaning cycle.

Control Logic:

Cleaning cycle is automatically initiated by:

- Differential pressure switch (ΔP)
- Adjustable timer
- Manual activation

Control Voltage:

24 VAC (standard control board) or 24 VDC (PLC compatible).

Continuous Operation:

Cleaning process is performed without interrupting downstream flow.

HOW IT WORKS

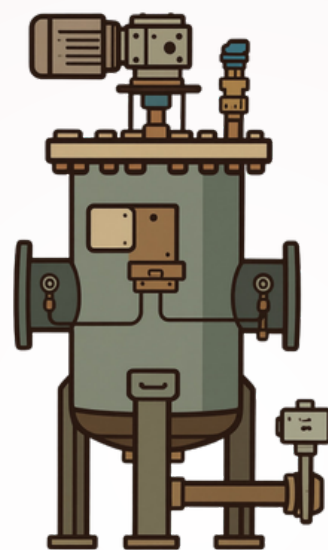

- 1 **Filtration:** Raw water enters from inlet, passes through patented "cross screen" cylinder to outlet.
- 2 **Detection:** ΔP switch senses pressure differential across screen (preset ~0.5 bar).
- 3 **Cleaning:** SS/Nylon brushes sweep inner screen surface; exhaust valve opens to flush debris.
- 4 **Continuous Flow:** Filtered water continues downstream during entire self-cleaning process.

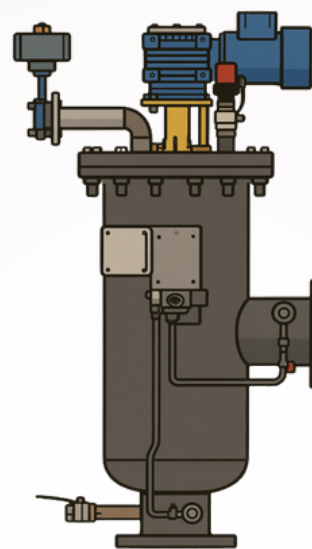

- 1 **Filtration:** Raw water enters from inlet, passes through the screen to the outlet.
- 2 **Detection:** ΔP switch senses pressure differential at preset value.
- 3 **Suction Scanning:** Scanner spirals across screen; exhaust valve creates high-velocity suction at nozzle tip.
- 4 **PLC Controlled:** Maximum flexibility — continuous flush mode, cycle counter, alarm output for bypass/pump control.

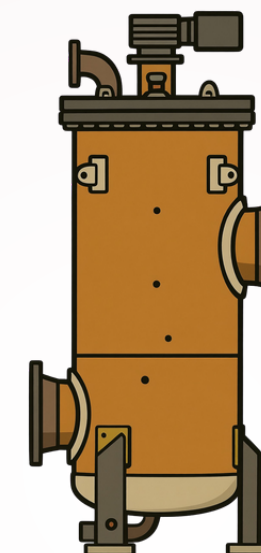

- 1 **Filtration:** Raw water enters from inlet, passes through screen cylinder to outlet.
- 2 **Detection:** Pressure differential switch triggers self-cleaning at preset value.
- 3 **PLC Controlled:** Continuous flush, cycle counter, alarm output for bypass/pump shutoff.



Industries We Serve



Sewage Treatment Industry

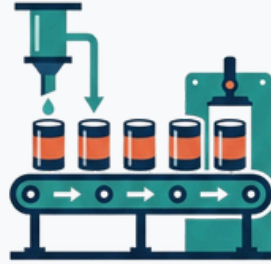

Food Processing Facilities



Cement Manufacturing



Chemical Plants



Petrochemical



Mining Operations



Pulp and Paper



Steel Mills

Why Choose Us



Engineering Excellence

Over 20 years of experience in pressure vessel and filtration equipment design and manufacturing. Our engineering team provides custom solutions tailored to your specific requirements.

Quality Assurance

All products manufactured to international standards (ASME, PED, EN13445) with comprehensive testing and third-party inspection. Full material traceability and documentation.



Global Support

Technical support, installation guidance, and after-sales service provided worldwide. Extensive spare parts inventory and fast delivery to minimize downtime.

Get in touch with us today!

EMAIL

info@pressurevesselequipment.com

PHONE

+90 541 925 20 14

WEBSITE

<https://www.pressurevesselequipment.com>

ADDRESS

İvedik OSB, İvedik Organize Sanayi Bölgesi,
1364. Sk. No:12, 06378 Yenimahalle/Ankara

Head Office
İvedik OSB, İvedik Organize Sanayi Bölgesi, 1364. Sk. No:12, 06378 Yenimahalle/Ankara

Manufacturing Facility
Malıköy Başkent OSB, 19. Cd. No:58, 06909 Sincan/Ankara

